

X2



INFORMATION

The Genesis 'X' series of sliding table panel saws must be one of the finest machines available on the market with every part of the machine designed for a purpose as opposed to a price. The structure of the machine and the construction are designed to withstand even the most demanding of cutting requirements with the frames being manufactured from heavy gauge steel which is laser cut and finger jointed ensuring strength and accuracy for the long term. Additional torsion bars are fitted to the base of the machine, again ensuring a structurally sound rigid base and frame, eliminating the possibility of flexing during operation and ensuring accurate and chip free cutting.

- 3200 mm sliding table of multi chamber construction running on solid and hardened steel runners with large diameter 'dumb bell rollers' to ensure an easy gliding motion.
- 1300mm rip fence mounted on a solid hardened and chromed 50mm diameter bar
- Fine adjustment to the rip fence
- Powerful 5.5 Kw (7.5Hp) motor
- 4 blade speeds by easily accessible manual belt change
- Independent scoring saw
- Machine is fitted with a NC keypad which gives motorised adjustments to:
 1. Raise and lower of the saw blade
 2. Tilt of the sawblades, numeric entry with LED digital display
 3. Raise, lower and lateral adjustment of the scorer
- Heavy duty, large section crosscut fence, telescopic with flat scales for ease of use.
- Quick release of cross cut fence for cutting solid wood or ripping larger panels.
- 2 x heavy duty flip stops, the action in a self lubricating bush to ensure long term accuracy.
- Self supported over head safety guard for better dust extraction and to allow possibility of grooving

- Maximum blade size 350mm diameter
- Maximum depth of cut 100mm
- Machine supplied with separate angle cutting fence

SPECIFICATION

Main saw blade diameter max.	Ø 350 mm
Max. cutting height with blade at 90°	100 mm
Max. cutting height with blade at 45°	70 mm
Rectified cast iron fixed table dimension	620x1000 mm
Main blade speed	3000 / 4000 / 5000 / 6000 RPM
Keypad control panel	
Sliding table length	380 x 3200 mm
Main saw bore	Ø 30 mm
Main motor power	7.5HP (5.5KW)
Scoring saw blade	Ø 120 mm
Scoring motor power	1HP (0.75KW)
Scoring blade speed	8000 RPM
Cutting width	1300mm
Saw table extension	800 mm
Cross cut fence manual movement	Yes
With Mitre fence	
Manual control for cutting width adjustment	
Digital control for blade tilting adjustment	
Motorized control for main saw height adjustment	
Motorized for scoring saw height adjustment	
Motorized for scoring + / - direction adjustment	
With Luxurious Overhead saw guard	
With keypad type control panel	
With tool frame	
With Clamping shoe	
Main channel dust collection	Ø 125 mm

Lux saw guard dust collection	Ø 75 mm
380V/50HZ/3PH	
Packing size	2270 x 1300 x 1100 mm + 3330 x 470 x 330 mm
N.W / G.W.	878 kg / 1050 kg + 187 kg / 247 kg

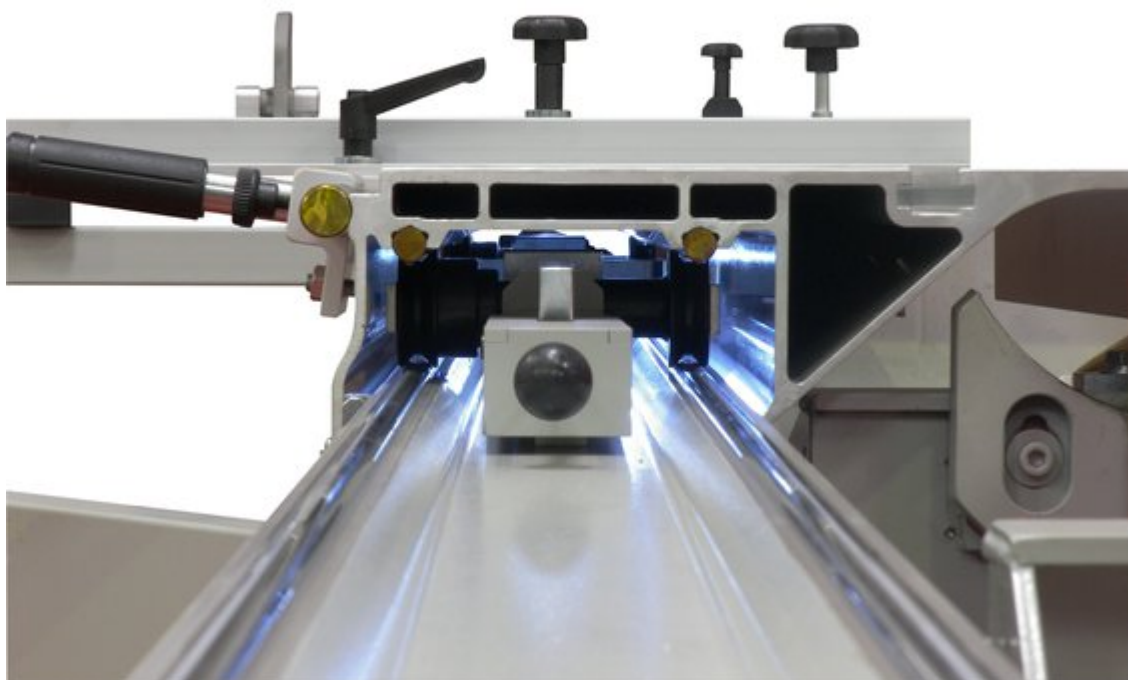

Heavy duty sliding table of multi chamber construction using solid hardened and chromed steel guides with large diameter 'dumb bell' rollers to ensure an easy glide.



Heavy duty flip stops

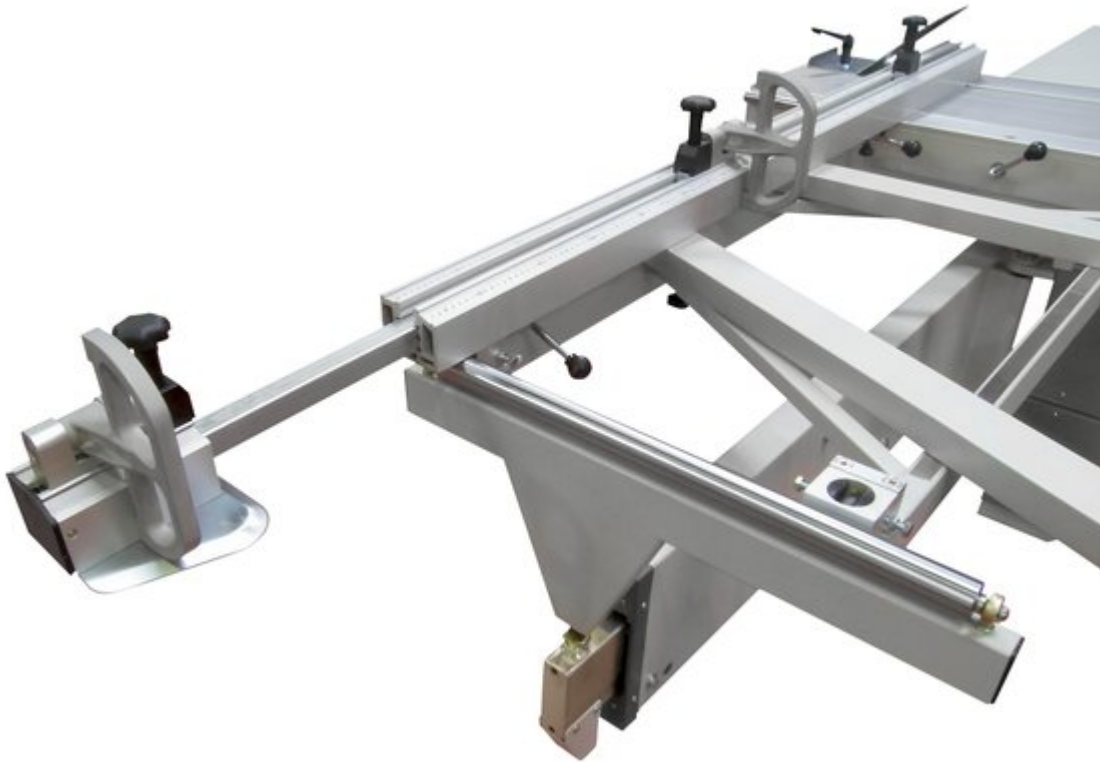

Heavy duty telescopic cross cut fence

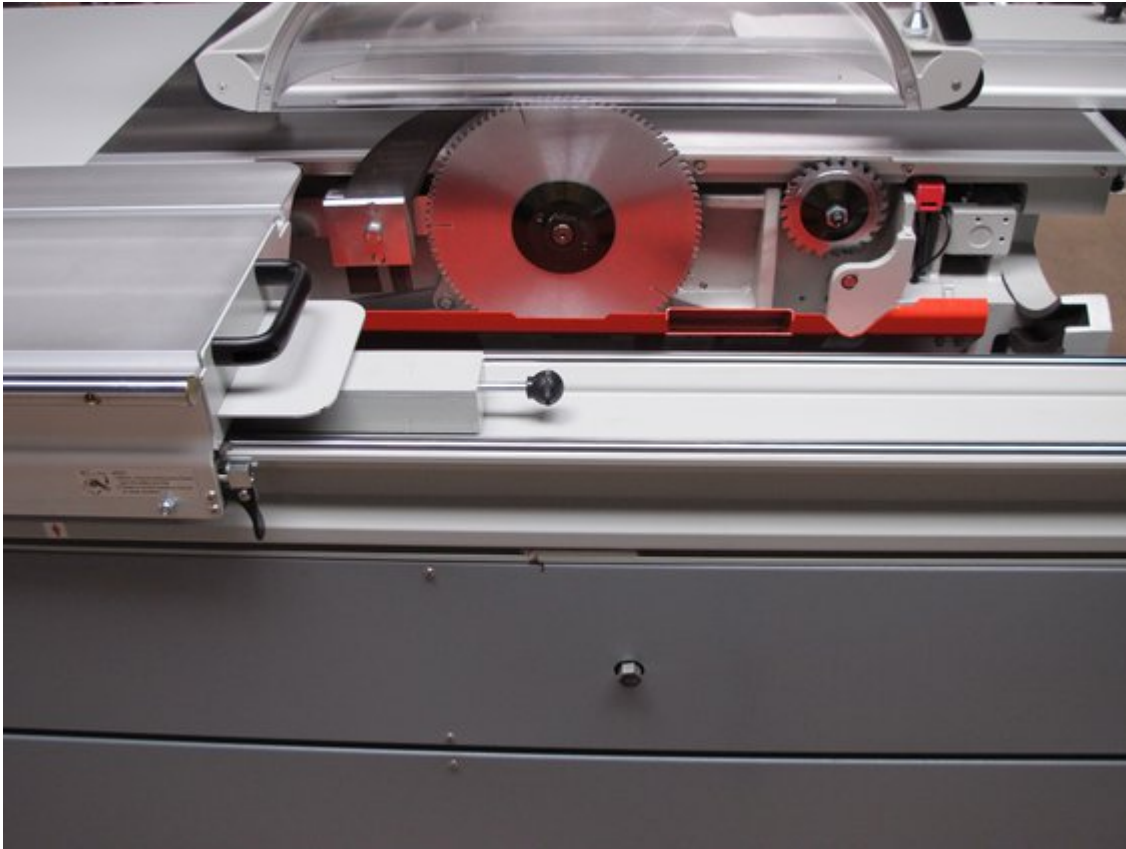

Easy access for blade change



Control panel

Find out more about this machine and the rest of the range at the [Genesis X-Type Panel Saws](#) website.

POA

PLEASE ENQUIRE FOR THE LATEST PRICING & AVAILABILITY INFORMATION FOR THIS ITEM

Download this
page as a PDF

See all items in...

- [Sliding table panel saws...](#)